

Dr. Maisch

Any Column, Any Size, Any Media

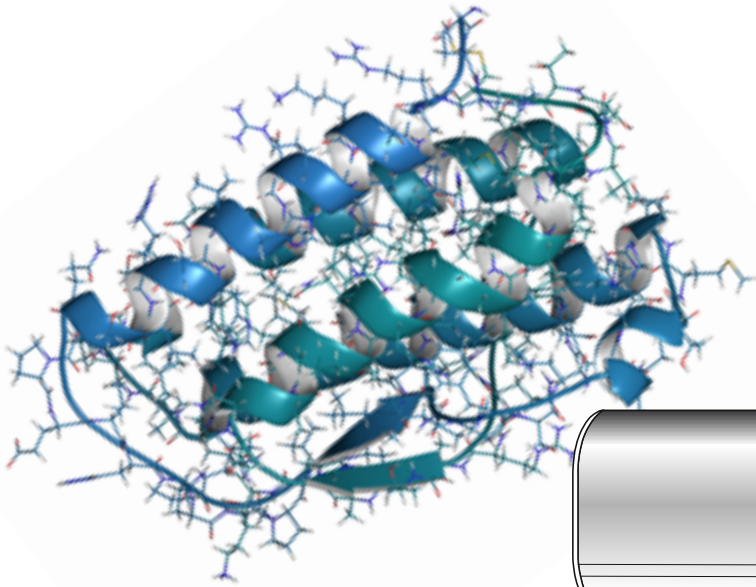

Trapping Cartridges & Holders for Proteomics

MADE BY DR. MAISCH

CONTENT

- P 4 INTRODUCTION
- P 5 TRAPPING STEPS
- P 6 TRAPPING SET-UP
- P 7 FEATURES, TECHNICAL DATA AND LOADING CAPACITY
- P 8 ORDERING INFORMATION
- P 9 POPULAR TRAPPING CARTRIDGES MADE BY DR.MAISCH
- P 10 - 11 TRAPPING CARTRIDGE INSTALLATION



**TRAPPING CARTRIDGES
& HOLDERS
MADE BY DR. MAISCH**

From one of the biggest
High-Performance Liquid Chromatography (HPLC) and
Ultra High-Performance Liquid Chromatography (UHPLC)
Column Manufacturers in Europe.

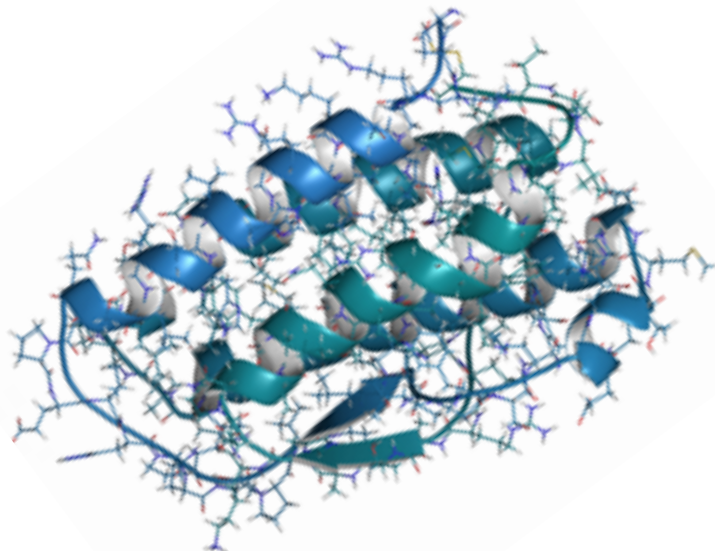

INTRODUCTION

In micro- and nanoscale LC, a Trapping Cartridge is often used before the analytical column. There are several reasons why trapping could be of interest:

- Sample **clean-up**.
- **Pre-concentration** of very low concentrated samples.
- **Removal** of salts and contaminants.
- **Extension** of life time of the analytical column.
- Increase of **sensitivity**.
- Increase of loading **speed** of the sample.
- Increase of volumetric load (= **higher mass load** on the column).

A Trapping Cartridge is a storage and cleaning area for the injected sample before the components are eluted and separated on the analytical column.

The typical approach to achieve this is to use a less retentive media in the Trapping Cartridge.

For C18 columns this could be:

- The same base silica but shorter alkyl chain modification (e.g. C8 instead of C18).
- Different C18 silica with less carbon load.
- Completely different media that is less retentive.

The analytes are refocused at the head of the analytical column after elution from the Trapping Cartridge.

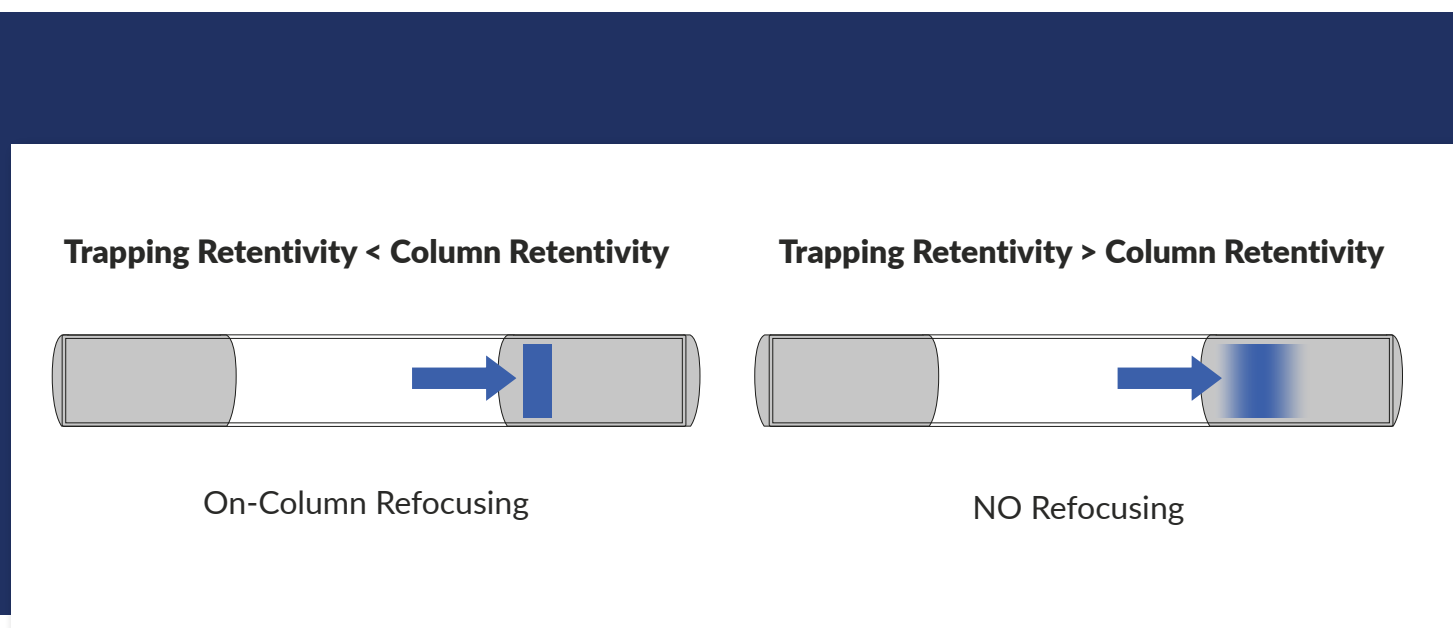

Figure 1: Illustration of the Trapping Mechanism.

TRAPPING STEPS

General Trapping Steps

Table 1: 3 steps of the Trapping Mechanism.

1) Loading	<p>Sample is injected and focused on the Trapping Cartridge at high flow rates in a short time.</p> <p>Larger inner diameter of the Trapping Cartridge and larger particles compared to analytical column.</p> <p>Injected analyte band is retained and focused near the inlet of the Trapping Cartridge.</p>
2) Cleaning (if needed)	<p>Impurities or unwanted species in the sample are washed from the Trapping Cartridge.</p> <p>Analytes of interest are retained.</p>
3) Elution	<p>Trapped analytes are reconstituted in the mobile phase and eluted onto the analytical column at lower flow rate suitable for the small bores of the nano LC-column.</p> <p>The elution step may be used in Forward-Trap-Elute and Reverse-Trap-Elute-Configuration.</p>

This trap-and-elute technique requires some time for method development. The advantages of a well-optimized trapping method definitely justify the effort for the reasons mentioned earlier.

TRAPPING SET-UP

Trapping Set-Up

Forward-Trap-Elute: Simple Set-Up

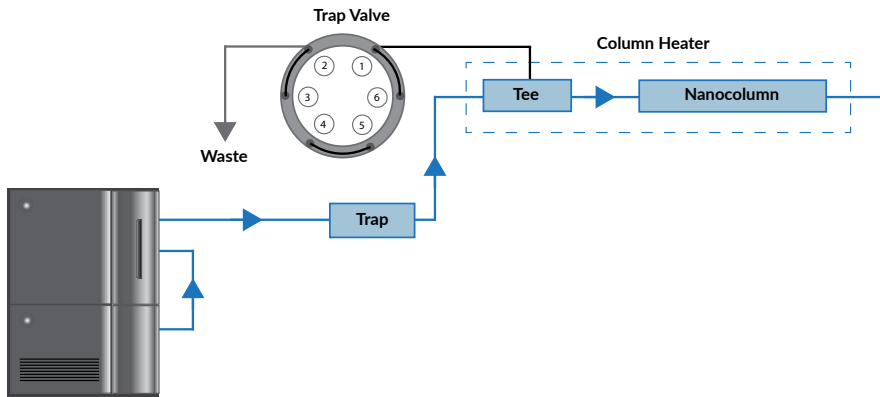

- The sample is eluted from the trap in the same flow direction as in the loading step.
- One flow path with added up backpressure (bp) but the “felt” bp is lower on the Trapping Cartridge.

Figure 2: Illustration of the Forward-Trap-Elute Set-Up.

Reverse-Trap-Elute: More sophisticated Set-Up

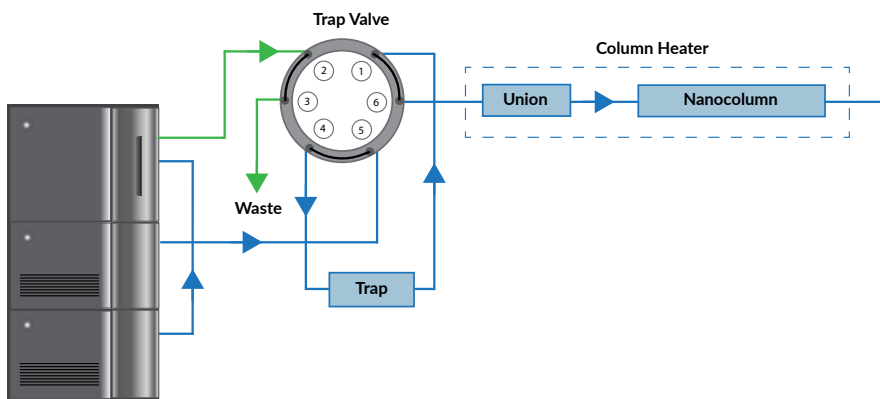

Figure 3: Illustration of the Reverse-Trap-Elute Set-Up.

Trapped Analytes of Interest

- Elution in reverse flow direction.
- Short distance migration along the packed bed.
- Less band broadening.
- Two separate flow paths with different backpressure.

FEATURES, TECHNICAL DATA AND LOADING CAPACITY

Features of the Dr. Maisch Trapping Cartridge Solution

- Utility-Patent: With a stopper on the outlet side (**auto-centering of the cartridge**).
- **Back and forward flush** of the mobile phase possible.
- Short sample loading times – **reduces** total HPLC analysis **run times**.
- Cartridge system allows **fast exchange** of Trapping Cartridges.
- Wide variety available.
- Wide variety of Trapping Cartridge dimensions available.
- **Suitable for PepMap™ Neo Trap Cartridge.**

Technical Data

Stainless steel cartridges with stainless steel fits on inlet and outlet side.

Pressure:	800 bar
Typical Particle Size:	3 µm or 5 µm Other particle sizes on request.
Package Size:	3 cartridges / pack
Holder:	2 different lengths available (5 mm and 10 mm) 3 different IDs available (0.3 mm, 0.5 mm, 1.0 mm)

Loading Capacity

Table 2: Loading Capacity and Technical Data of the available Dr. Maisch Trapping Cartridges.

Length [mm]	ID [mm]	Density [kg/m ³]	Volume [ml]	Used Media	Media Amount [µg]	Loading Capacity 5% [µg]
5	0.3	600	0.4	C18 Silica-Media	212	11
5	0.5	600	1.0		589	29
5	1.0	600	3.9		2356	118
10	0.3	600	0.7		424	21
10	0.5	600	2.0		1178	59
10	1.0	600	7.9		4712	236

ORDERING INFORMATION

Ordering Information



Figure 4: Trapping Cartridge and Holder.

Table 3: Available 5 mm Trapping Cartridges.



Description	Dimension [mm]	Part Number (PN)
Cartridges (3/pck)	5 x 0.3	media code.t000.3
Cartridges (3/pck)	5 x 0.5	media code.t000.5
Cartridges (3/pck)	5 x 1.0	media code.t0001
Trapping Cartridge Holder - short (with standard PEEK-Fingertights for 1/32" capillaries)	5.0	FSH.05

Figure 5: Trapping Cartridge (5 x 0.3 mm).

Table 4: Available 10 mm Trapping Cartridges.



Description	Dimension [mm]	Part Number (PN)
Cartridges (3/pck)	10 x 0.3	media code.t010.3
Cartridges (3/pck)	10 x 0.5	media code.t010.5
Cartridges (3/pck)	10 x 1.0	media code.t0101
Trapping Cartridge Holder FS (with standard PEEK-Fingertights for 1/32" capillaries)	10	FSH.01

Figure 6: Trapping Cartridge (10 x 0.3 mm).

POPULAR TRAPPING CARTRIDGES MADE BY DR. MAISCH

Popular Trapping Cartridges made by Dr. Maisch

ReproSil-Pur 120 C18-AQ

Table 5: Technical Data of the available Trapping Cartridges packed with ReproSil-Pur 120 C18-AQ.

Media	Modification	Pore Size [Å]	Surface Area [m ² /g]	Carbon Load [%]	Particle Size [µm]	Length [mm]	ID [mm]	Cartridge Holder PN	Part Number (PN)
ReproSil-Pur 120 C18-AQ	C18	120	300	15	5	5	0.3	FSH.05	r15.aq.t000.3
	C18	120	300	15	5	10	0.3	FSH.05	r15.aq.t010.3
	C18	120	300	15	5	10	0.5	FSH.05	r15.aq.t010.5
	C18	120	300	15	5	5	0.3	FSH.05	r13.aq.t000.3
	C18	120	300	15	5	10	1.0	FSH.05	r13.aq.t0101
	C18	120	300	15	5	10	0.5	FSH.05	r13.aq.t010.5

- ReproSil-Pur 120 C18-AQ, 1.9 µm is the golden standard in many Proteomics labs for packed capillary columns.
- Pore Size of 120 Å is suitable for molecules <10 kDa.
- Larger particles (3 µm, 5 µm) are recommended for Trapping Cartridges.
- Moderate Surface Area (loadability) and Carbon Load (hydrophobicity).

ReproSil Saphir

Table 6: Technical Data of the available Trapping Cartridges packed with ReproSil Saphir.

Media	Modification	Pore Size [Å]	Surface Area [m ² /g]	Carbon Load [%]	Particle Size [µm]	Length [mm]	ID [mm]	Cartridge Holder PN	Part Number (PN)
ReproSil Saphir	C18	100	400	20	5	5	0.5	FSH.01	ra15.9e.t000.3
	C8	100	400	12	5	5	0.3	FSH.05	ra15.4e.t000.3
	C4	100	400	4	5	5	0.3	FSH.05	ra15.8e.t000.3

- ReproSil Saphir C18, 1.5 µm media shows a very high efficiency packed in capillary columns and growing popularity.
- Pore Size of 100 Å is suitable for molecules <10 kDa.
- Bigger particles (5 µm) are recommended for Trapping Cartridges.
- High Surface Area (loadability) and high Carbon Load.
- Hydrophobicity C18 > C8 > C4.
- ReproSil Saphir C18 is an excellent alternative to PepMap™ Neo C18, 5 µm from Thermo Scientific.

ReproSil Wide Pore Media

Table 7: Technical Data of the available Trapping Cartridges packed with ReproSil wide pore media.

Media	Modification	Pore Size [Å]	Surface Area [m ² /g]	Carbon Load [%]	Particle Size [µm]	Length [mm]	ID [mm]	Cartridge Holder PN	Part Number (PN)
ReproSil-XR	C8	300	100	5	5	5	0.3	FSH.05	rx35.8e.t000.3
ReproSil-XR	C4	300	120	3	5	5	0.3	FSH.05	rx35.4e.t000.3
ReproSil-Gold	C4	300	100	8	5	10	0.3	FSH.01	r35.4g.t010.3

- 300 Å media for the analysis of biomolecules >10 kDa.
- Bigger particles (5 µm) are recommended for Trapping Cartridges.
- C4 media is used for most biomolecules.
- ReproSil-XR C4 is less hydrophobic than ReproSil Gold C4.

www.dr-maisch.com

TRAPPING CARTRIDGE INSTALLATION

Trapping Cartridge Installation

- 2 different holders for 2 different cartridge lengths available.

FSH.05 for 5 mm cartridges with $\frac{1}{16}$ " connection.

FSH.01 for 10 mm cartridges with $\frac{1}{16}$ " connection.

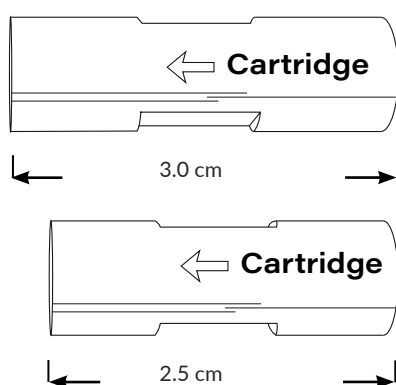

Figure 7: Trapping Cartridge Holder FSH.05 and FSH.01.

The 3 different IDs (0.3 mm, 0.5 mm and 1 mm) fit all in the same holder.

- Insert the cartridge in the indicated direction on the holder ($\frac{1}{16}$ ").

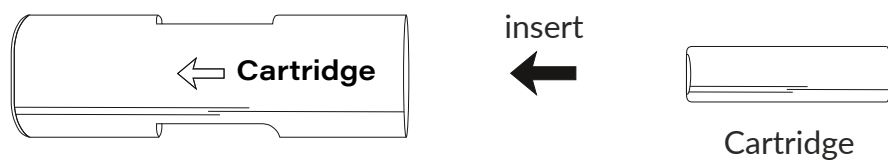

Figure 8: Trapping Cartridge Holder and Trapping Cartridge.

TRAPPING CARTRIDGE INSTALLATION

- Trapping Cartridge Holder (with standard PEEK-Fingertights for $1/32''$ capillaries) (FSH.01 and FSH.05)



Figure 9: Trapping Cartridge (FSH.01), Trapping Cartridge (FSH.05) and $1/32''$ Thread.

- Suitable for Nanoviper & Marvel XACT (Zero Dead Volume Connection).

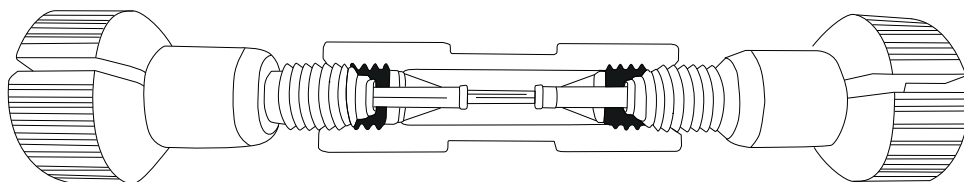
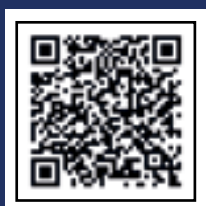

Figure 10: Cross-Section of the Trapping Cartridge Holder, Trapping Cartridge and Nanoviper & Marvel XACT.

- Visit our Dr. Maisch YouTube channel to watch our installation tutorials.



Dr. Maisch

Any Column, Any Size, Any Media

Distributor:



Dr. Maisch HPLC GmbH
Beim Brückle 14
D-72119 Ammerbuch
T: +49 (0) 7073 50357
F: +49 (0) 7073 4216
www.dr-maisch.com
www.modcol.com
info@dr-maisch.com



PDF brochure
for download